



aerospace
climate control
electromechanical
filtration
fluid & gas handling
hydraulics
pneumatics
process control
sealing & shielding



Compressed Air & Gas Filters

High Efficiency Coalescing Filters



ENGINEERING YOUR SUCCESS.

Why Filter Compressed Air?

Product rejects and increased maintenance expenses can occur due to poor air quality

Submicronic contaminants in compressed air systems plug orifices of sensitive pneumatic instrumentation, wear out seals, erode system components, reduce the absorptive capacity of desiccant air/gas dehydrators, foul heat transfer surfaces, reduce air tool efficiency, and damage finished products. The results include product rejects, lost production time and increased maintenance expense. For example, trace amounts of submicronic oil can cause serious fish eye

blemishing in automotive finishing operations. Water left in air lines can freeze during exposure to cold temperatures, blocking flow or rupturing pipes. Compressor lubricant not captured in a coalescing filter will eventually collect in pneumatic components, causing premature component repair or replacement. Environmental concerns will be raised if oily, compressed air is continually discharged into the atmosphere through a pneumatic muffler.



Finite filters are used everyday in food grade applications.

Finite's H-Series Offers...

- **Coalescing, particulate and adsorption filter elements**
- **Optional indicators, gauges and drains**
- **Temperatures to 450° F (232° C)**
- **Pressures to 500 PSIG (34 bar)**
- **Connection sizes from 1/4" to 3" NPT, BSPP & BSPT**
- **Flows from 10 to 1660 SCFM (17-2822 m³/hr)**



Manufacturing plants use compressed air in a variety of automated processes.

Why Use Finite Filters?

Element formation

Our special UNI-CAST formed elements provide lower pressure drop and less frequent changeouts, saving you time and money.

We meet your needs

Finite offers a variety of filter elements to meet your application requirements.

Technical support

We are committed to providing unmatched technical support to all of our customers.

Short lead times

Our LEAN manufacturing capability assures that you will have the right filter product at the right time. Popular products are shipped in three days.

Typical Applications

(See Pages 4-5 for application and air cleanliness schematics)

Coalescing (Oil Removal)
Air dryer prefilter
Paint spray booths
Breathing air
Tool protection
Air valve protection
Air cylinder protection
Natural gas filtration
Technical gas filtration
Interceptor (Particulate Removal)
Desiccant dryer afterfilter
Prefilter for coalescer
Systems with high concentrations of solid contaminant
Particulate protection for non-lubricated systems
Adsorber (Vapor Removal)
Odor removal
Breathing air
Food packaging equipment
High purity laboratory gases
Hydrocarbon vapor removal



Four steps to clean, dry compressed air and gas.

Step 1.

Determine your application, media grade, media type and end seal material.
Pages 4-7

Step 2.

Choose your housing and replacement elements.
Pages 8-9

Step 3.

Choose your accessories. Find out what's standard or choose what's best for your application.
Page 9

Step 4.

How to Order. Build your own part number here!
Page 10

Sources of Contamination

Compressed air and gas lines typically contain water, oil and particulate contamination

The contaminants of greatest concern in precision compressed air systems are water, oil and solids.

Water vapor is present in all compressed air and it becomes greatly concentrated by the compression process. While air dryer systems can be used

effectively to remove water from compressed air, they will not remove the second major liquid contaminant - oil.

Most oil comes from compressor lubrication carry-over, but even the air produced by oil-free compressors has hydrocarbon contamination

brought into the system through the intake.

The third contaminant is solid matter including dirt, rust and scale. Solid particulates, combined with aerosols of water and oil, can clog and shorten the life of air system components and can foul processes.

Compressed Air Standards and Applications

From aeration in pharmaceutical and chemical processes to pneumatic power systems, the possibilities for applications are endless. Finite has some suggested air cleanliness standards that may fit your needs.

International Standard ISO8573-1 has become the industry standard method for specifying compressed air cleanliness. The following diagrams describe various systems in terms of their corresponding ISO classification.

International ISO Standards							
Notification as specified in ISO8573 - 1 (1991)							
Class	Maximum Particle Size	Solid		Water		Oil	
		Maximum Concentration*	Maximum Concentration*	Maximum Pressure Dewpoint	Maximum Pressure Dewpoint	Maximum Concentration*	Maximum Concentration*
	(μm)	ppm	mg/m^3	$^{\circ}\text{F}$	$^{\circ}\text{C}$	ppm	mg/m^3
1	0.1	0.08	(0.1)	-94	(-70)	0.008	(0.01)
2	1	0.8	(1)	-40	(-40)	0.08	(0.1)
3	5	4.2	(5)	-4	(-20)	0.83	(1)
4	15	6.7	(8)	37	(+3)	4.2	(5)
5	40	8.3	(10)	45	(+7)	21	(25)
6	-	-	-	50	(+10)	-	-

*At 14.7 psi (1 bar) absolute pressure, +70°F (+20°C) and a relative humidity of 60%. It should be noted that at pressures above atmospheric, the contaminant concentration is higher.

Notes:

1. The quality of the air delivered by non-lubricated compressors is influenced by the quality of the intake air and the compressor design.

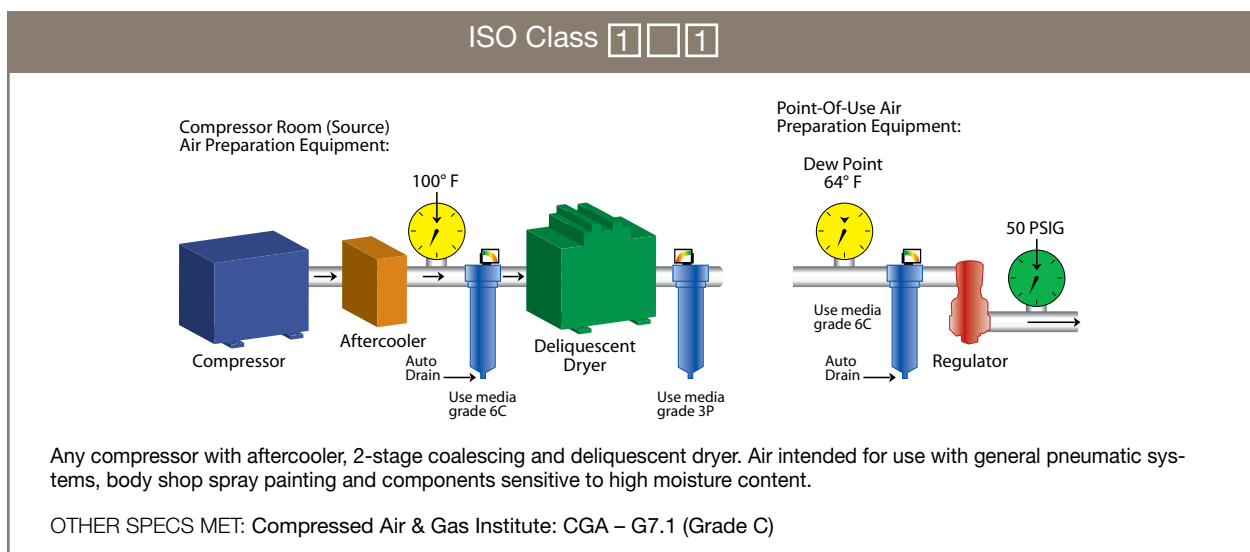
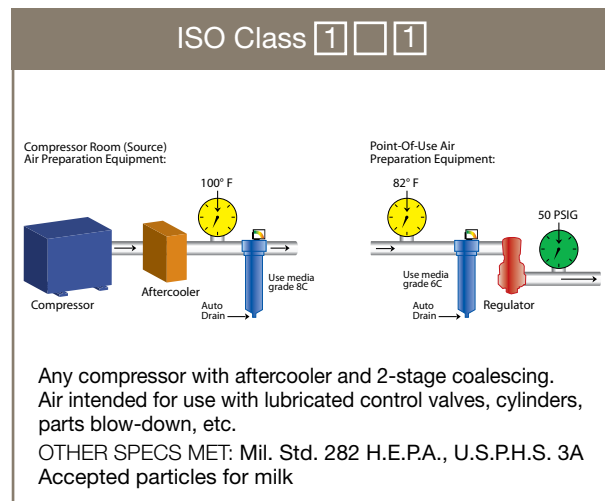
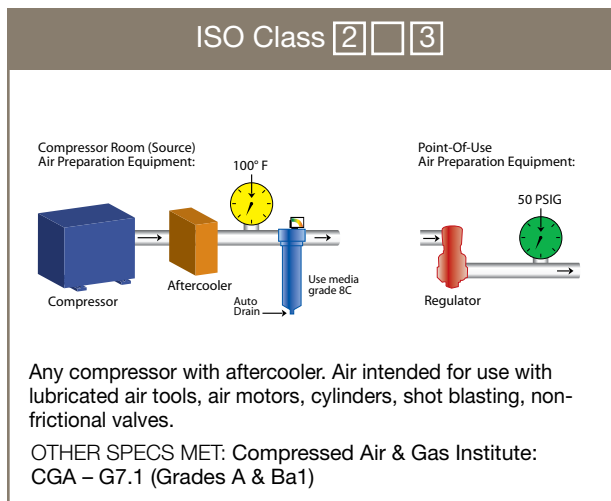

ISO Class 1 4 1

Compressor Room (Source)
Air Preparation Equipment:

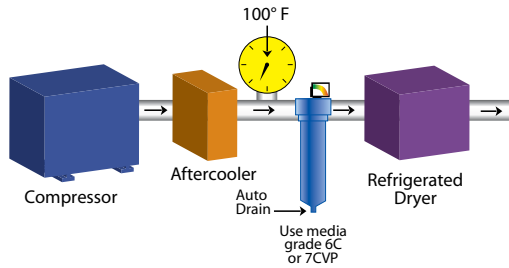

Point-Of-Use
Air Preparation Equipment:

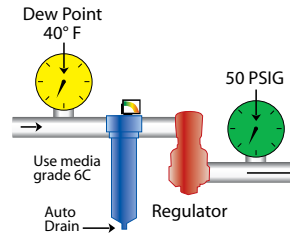

Any compressor with aftercooler, 2-stage coalescing and refrigerated dryer. Air intended for use with air-gauging, air conveyors, spray-painting, food processing, instrumentation, blow molding, cosmetics, film processing, bottling, pharmaceuticals, dairy, breweries, medical, robotics and close tolerance valves.

SPECS MET: CGA – G7.1 (Grades D & E), ISAS7.3 Fed. Std. 209 (Class 100)

ISO Class 1 4 1

Compressor Room (Source)
Air Preparation Equipment:

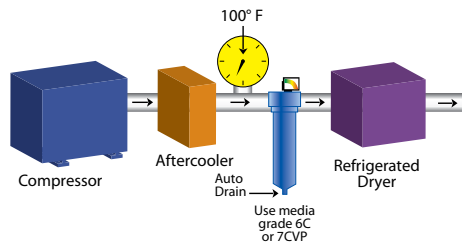

Point-Of-Use
Air Preparation Equipment:

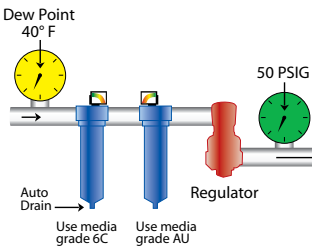

Any compressor with aftercooler, 2-stage coalescing, refrigerated dryer and carbon absorber. Air intended for use as industrial breathing air and decompression chambers. CAUTION: Always use high temperature synthetic lubricants and monitor (alarm for carbon monoxide concentrations). This system will not eliminate toxic gases!

OTHER SPECS MET: O.S.H.A. 29CFR 1910.134

ISO Class 1 2 1

Compressor Room (Source)
Air Preparation Equipment:

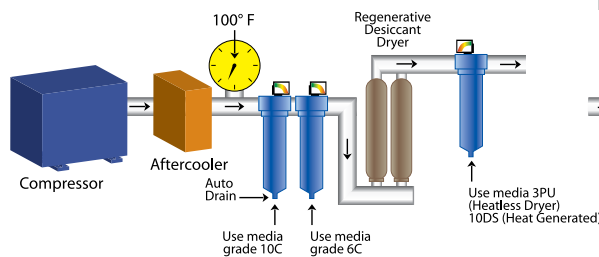

Point-Of-Use
Air Preparation Equipment:

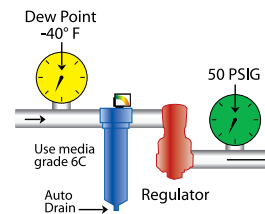

Any compressor with aftercooler, two-stage and double coalescing and a regenerative-type desiccant dryer. Air intended for use in applications involving rapid expansion of compressed air, critical instrumentation, high purity gases, computer chip drying, etc. CAUTION: This air is too dry for respiratory use.

SPECS MET: CGA – G7.1 (Grade F)

Step 1. Determine your application, media grade, media type and end seals.

Find your (or similar) application from the descriptions below, from the basic application circuits on the previous page, or consult a Finite application engineer. Determine media grade, media type and end seal required. If your application requires a coalescing element, use the information listed below. For other media types, please see the following page.

Coalescing Elements (removal of liquids and particulate)

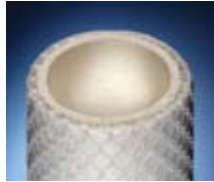

Media type C

Available in grades 4,6,8 or 10
Air Flow: Inside to Outside

This coalescing element is made with our special UNI-CAST construction. Composed of an epoxy saturated, borosilicate glass micro-fiber media, this media is used in applications requiring the removal of liquid and particulate contamination. The outer synthetic fabric layer allows swift removal of coalesced liquids.

Media type I is constructed similarly to the C media but also includes an inner retainer intended for additional strength where reverse flow is likely.

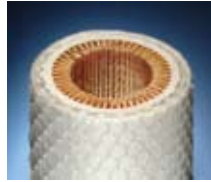

Media type Q

Available in grades 4,6,8 or 10
Air Flow: Inside to Outside

This coalescing element is composed of an epoxy saturated, borosilicate glass micro-fiber media, and is also made with our special UNI-CAST construction. This media type has a built-in pleated cellulose prefilter as the inner layer. As with the C and I media types, the outer synthetic fabric layer aids in the swift and efficient removal of coalesced liquids.

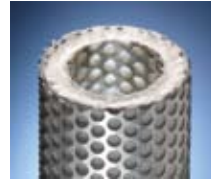

Media type D

Available in grades 4,6,8 or 10
Air Flow: Inside to Outside

Media type D elements are composed of a micro-glass coalescer, utilize a special high temperature UNI-CAST formulation, but are surrounded by inner and outer diameter metal retainers. These metal retainers, coupled with a glass drain layer, make this an extremely robust element designed to remove both solid and liquid contaminants at elevated temperatures.

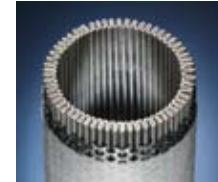

Media type 7CVP or ME

Only available in 1/4" NPT port size housings and larger
Air Flow: Inside to Outside

Finite's 7CVP media type consists of two filter layers between metal retainers. The outer layer removes aerosols while the inner layer traps solid particles, protecting and extending the life of the outer layer. 7CVP elements are used in bulk liquid coalescing applications or when relatively high efficiency and low pressure drop are required. A special 7DVP media is constructed the same way, however it allows for higher temperature applications.

Finite's ME media type are mist eliminator elements that are constructed similarly to the 7CVP, but offer even higher filtration efficiency for more critical compressed air quality demands.

For types C, D, I and Q... Choose your grade...

Grade 4

Finite's media grade 4 is typically chosen when an extremely high coalescing efficiency is required. Its 99.995% rating is the best available and is ideal for use as a final filter in applications with elevated operating pressures (up to 500 PSIG), or when removing liquid contaminants from gases lighter than compressed air.

Grade 6 (Standard)

Grade 6 filters are used when "total removal of liquid aerosols and suspended fines" is required. Because of its overall performance characteristics, this grade is most often recommended in a variety of industrial applications. Grade 6 is an excellent choice as a prefilter for regenerative desiccant air dryers, as it prevents oil or varnish from coating the desiccant.

Grade 8

Grade 8 filters combine high efficiency (98.5%) with high flow rate and long element life. A separate prefilter is not required for "normal to light" particulate loading. A grade 8 element is often chosen as protection for refrigerated air dryers. This element allows the dryer to maintain efficiency by preventing the coating of copper coils with the build-up of oil or varnish.

Grade 10

Grade 10 filters are used as prefilters for grades 6 or 8 to remove gross amounts of liquid aerosols or tenacious aerosols. Grade 10 is often referred to as a coarse coalescer, or precoalescer. A grade 10 in a media type D filter element is recommended as an afterfilter for heat regenerated desiccant type air dryers as its one micron rating is ideal for collecting air dryer desiccant fines before they pass downstream.

Water Separator Element (removal of bulk liquids)

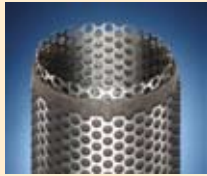

Media type 100WS

Air Flow: Inside to Outside

This rolled stainless steel mesh element has ID and OD metal retainers with rolled stainless steel mesh in between. It is an extremely robust design. With a nominal rating of 100 micron, this media is used for the reduction and elimination of excess liquids in gas streams. It also would be a good choice as a prefilter for coalescing grades 6 and 10 when extreme volumes of liquid contaminants are present.

Interceptor Element (removal of solids)



Media type 3P

Air Flow: Outside to Inside

Finite's 3P pleated cellulose element removes solid contaminants, with a 3 micron absolute rating. Because this element is designed to flow from its outside to the inside, it has a strong inner retainer that gives this element added strength. 3P particulate "Interceptor" elements are used where very high dirt loading is expected but a relatively fine pore structure is required. It is also used as a prefilter to a coalescing filter in systems where a lot of solid contamination exists.

Adsorption Element (removal of odor)



Media type A

Air Flow: Outside to Inside

This hydrocarbon vapor removal element consists of an ultra-fine grained, highly concentrated, activated carbon sheet media. Because these elements are designed to flow from the outside to their inside, they have a strong inner retainer giving this element added strength. This media type is used to remove hydrocarbon vapor and is often used to remove the smell or taste of compressor lube oil from breathing air.

Finite Media Specifications

Grade Designation	Coalescing Efficiency 0.3 to 0.6 Micron Particles	Maximum Oil Carryover ¹ PPM w/w	Micron Rating	Pressure Drop (PSID) @ Rated Flow ²	
				Media Dry	Media Wet With 10-20 wt. oil
4	99.995%	0.003	0.01	1.25	3-4
6	99.97%	0.008	0.01	1.0	2-3
ME	99.95%	0.02	0.3	0.5	1.0
7	99.5%	0.09	0.5	0.25	0.5-0.7
8	98.5%	0.2	0.5	0.5	1-1.5
10	95%	0.85	1.0	0.5	0.5
100WS	99+ ³	N/A	100	<0.25	<0.25
3P	N/A	N/A	3.0	0.25	N/A
A	99+ ⁴	N/A	3.0	1.0	N/A

¹Tested per ISO 12500-1 at 40 ppm inlet.

²Add dry + wet for total pressure drop.

³Bulk liquid removal efficiency.

⁴Oil vapor removal efficiency is given for A media.

End Seals available:

End Seals	Available on Media type:	Max temp of element with end seal
No end seals. Element are self sealing.	C	175°F (79°C)
U: Molded Urethane (standard)	C	175°F (79°C)
	I	
	Q	
	3P	
	100WS	
S: Molded Silicone Rubber	A	175°F (79°C)
	C	
	Q	
	D	
	3P	
V: Fluorocarbon gaskets on metal end caps	C	350°F (177°C)
	Q	350°F (177°C)
	D	450°F (232°C)
	ME	175°F (79°C)
	7CVP	175°F (79°C)
Note: V option is only available on 1¼" NPT and larger. Standard on all 7CVP, 7DVP, ME and 100WS media.	7DVP	400°F (204°C)
	100WS	450°F (232°C)
	3P	350°F (177°C)
	A	175°F (79°C)

Step 2. Determine your housing

Find your desired flow rate under the appropriate media grade column. For pressures other than 100 PSIG or temperatures other than 70°F, please see Alternate Housing Selection Chart, Step 2a, on following page.

Note: The housing assembly part numbers below have a NPT connection. For BSPP, insert F in place of N. For BSPT, insert T in place of N.

Housing Selection Chart

Rated Flows: SCFM @ 100 PSIG (m³/hr @ 7 bar)

For other pressures, please see Step 2a on following page.

Housing Assembly	Port Size	Grade 4 Coalescer	Grade 6 Coalescer (Standard)	Grade 7CVP Coalescer (or ME Media)	Grade 8 Coalescer	Grade 10 Coalescer	Grade 3PU Interceptor	Grade 100WS Water Separator	Grade A Adsorber
HN1S	1/4"	11 (19)	15 (26)	N/A	20 (34)	25 (43)	25 (43)	50 (85)	15 (26)
HN15S	3/8"	15 (26)	20 (34)	N/A	27 (46)	33 (56)	33 (56)	66 (112)	20 (34)
HN2S	1/2"	19 (32)	25 (43)	N/A	34 (58)	42 (71)	42 (71)	83 (141)	25 (43)
HN1L	1/4"	23 (39)	30 (51)	N/A	41 (68)	50 (85)	50 (85)	50 (85)	30 (51)
HN15L	3/8"	30 (51)	40 (68)	N/A	55 (94)	66 (112)	66 (112)	66 (112)	40 (68)
HN2L	1/2"	38 (65)	50 (85)	N/A	68 (116)	83 (141)	83 (141)	83 (141)	50 (85)
HN3S	3/4"	61 (104)	80 (136)	N/A	109 (185)	133 (226)	133 (226)	133 (226)	80 (136)
HN4S	1"	76 (129)	100 (170)	N/A	136 (231)	166 (282)	166 (282)	232 (394)	100 (170)
HN4L	1"	106 (180)	140 (238)	N/A	191 (325)	232 (394)	232 (394)	232 (394)	140 (238)
HN5S	1 1/4"	190 (323)	250 (425)	415 (706)	330 (461)	415 (706)	415 (706)	415 (706)	250 (425)
HN6S	1 1/2"	260 (442)	350 (595)	600 (1020)	465 (791)	600 (1020)	600 (1020)	600 (1020)	350 (595)
HN8E	2"	260 (442)	350 (595)	600 (1020)	465 (791)	600 (1020)	600 (1020)	600 (1020)	350 (595)
HN8S	2"	340 (578)	450 (765)	750 (1275)	600 (1020)	750 (1275)	750 (1275)	750 (1275)	450 (765)
HN8L	2"	470 (799)	625 (1063)	1035 (1760)	830 (1411)	1035 (1760)	1035 (1760)	1035 (1760)	625 (1063)
HN0L	2 1/2"	600 (1020)	800 (1360)	1330 (2261)	1060 (1802)	1330 (2261)	1330 (2261)	1330 (2261)	800 (1360)
HN12L	3"	750 (1275)	1000 (1700)	1660 (2822)	1330 (2261)	1660 (2822)	1660 (2822)	1660 (2822)	1000 (1700)

Replacement Element Part Numbers

*Insert selected media grade 4, 6, 8, 10.

Housing Assembly	Coalescer	Coalescer w/inner retainer	High Temperature	Coalescer w/ built-in prefilter	ME Mist Eliminator	7CVP Pleated Coalescer	3PU Interceptor	100WS Water Separator	AU Adsorber
HN1S	*C10-025	*IU10-025	*DS10-025	*QU10-025	N/A	N/A	3PU10-025	100WSU10-025	AU10-025
HN15S	*C10-025	*IU10-025	*DS10-025	*QU10-025	N/A	N/A	3PU10-025	100WSU10-025	AU10-025
HN2S	*C10-025	*IU10-025	*DS10-025	*QU10-025	N/A	N/A	3PU10-025	100WSU10-025	AU10-025
HN1L	*C10-050	*IU10-050	*DS10-050	*QU10-050	N/A	N/A	3PU10-050	100WSU10-025	AU10-050
HN15L	*C10-050	*IU10-050	*DS10-050	*QU10-050	N/A	N/A	3PU10-050	100WSU10-025	AU10-050
HN2L	*C10-050	*IU10-050	*DS10-050	*QU10-050	N/A	N/A	3PU10-050	100WSU10-025	AU10-050
HN3S	*C15-060	*IU15-060	*DS15-060	*QU15-060	N/A	N/A	3PU15-060	100WSU15-060	AU15-060
HN4S	*C15-060	*IU15-060	*DS15-060	*QU15-060	N/A	N/A	3PU15-060	100WSU15-060	AU15-060
HN4L	*C15-095	*IU15-095	*DS15-095	*QU15-095	N/A	N/A	3PU15-095	100WSU15-060	AU15-095
HN5S	*CU25-130	*CU25-130	*DS25-130	*QU25-130	ME25-130	7CVP25-130	3PU25-130	100WS25-130	AU25-130
HN6S	*CU25-130	*CU25-130	*DS25-130	*QU25-130	ME25-130	7CVP25-130	3PU25-130	100WS25-130	AU25-130
HN8E	*CU25-130	*CU25-130	*DS25-130	*QU25-130	ME25-130	7CVP25-130	3PU25-130	100WS25-130	AU25-130
HN8S	*CU25-187	*CU25-187	*DS25-187	*QU25-187	ME25-187	7CVP25-187	3PU25-187	100WS25-187	AU25-187
HN8L	*CU25-235	*CU25-235	*DS25-235	*QU25-235	ME25-235	7CVP25-235	3PU25-235	100WS25-235	AU25-235
HN0L	*CU35-280	*CU35-280	*DS35-280	*QU35-280	ME35-280	7CVP35-280	3PU35-280	100WS35-280	AU35-280
HN12L	*CU35-280	*CU35-280	*DS35-280	*QU35-280	ME35-280	7CVP35-280	3PU35-280	100WS35-280	AU35-280

Step 2a. Alternate Housing Selection Chart

Use this step for applications with technical gases or for applications that do not have standard conditions (100 PSIG and 70°F).

Because the required size of a filter is affected not only by flow, but also by operating pressure and operating temperature, it is necessary to convert those actual conditions to standardized conditions (100 PSIG and 70°F). The calculated adjusted flow rate can then be used to choose the appropriate filter in the chart on the previous page. When using the chart, choose the closest flow rate from the appropriate media grade column.

Note: Take the square root of your specific gravity. If this is for a compressed air application, skip this step because the specific gravity of air equals one. Please see chart to the right for specific gravities.

Gas	Specific Gravity
Air	1
Ammonia	0.58
Argon	1.37
Carbon Dioxide	1.52
Carbon Monoxide	0.96
Chlorine	2.48
Ethane	1.04
Ethylene	0.97
Helium	0.13
Hexane	2.73
Hydrogen	0.06
Methane	0.55
Natural Gas	0.66
Neon	0.69
Nitrogen	0.96
Oxygen	1.18
Pentane	2.47
Propane	1.56

Refer to this chart if you do not know the specific gravity of the gas you are filtering.

Equation								
Flow Rate:		Pressure:		Temperature:		Specific Gravity: (See chart above)		Adjusted Flow Rate:
Actual System Flow Rate (SCFM)	X	$\frac{(100 \text{ PSIG} + 14.7 \text{ PSIG})}{(\text{System Pressure (PSIG)} + 14.7 \text{ PSIG})}$	X	$\frac{(\text{System Temp. } ^\circ\text{F} + 460^\circ\text{F})}{70^\circ\text{F} + 460^\circ\text{F}}$	X	$\sqrt{\quad}$	=	SCFM @ 100 PSIG, 70°F

Example:

Information Given:
Flow Rate = 136 SCFM
Pressure = 150 PSIG
Actual Temperature = 100°F

$$136 \text{ SCFM} \times \frac{(100 \text{ PSIG} + 14.7 \text{ PSIG})}{(150 \text{ PSIG} + 14.7 \text{ PSIG})} \times \frac{(100^\circ\text{F} + 460^\circ\text{F})}{70^\circ\text{F} + 460^\circ\text{F}} \times \sqrt{1} = 100 \text{ SCFM}$$

Now go to the chart on page 8, look down the media grade 6 column for a flow of 100 SCFM, you will see the correct housing is the HN4S.

Step 3. Accessories

Consult Finite when choosing pre-installed accessories for gases other than air.

Pre-installed Accessories

Accessory Designator	Installed with...	Maximum Pressure	Maximum Temperature
A	Auto Drain	250 PSIG (17 bar)	175°F (79°C)
D	DPI Indicator	250 PSIG (17 bar)	175°F (79°C)
G	DPG Gauge	500 PSIG (34 bar)	175°F (79°C)
J	High Temp	250 PSIG (17 bar)	450°F (232°C)
N	No Accessories	500 PSIG (34 bar)	175°F (79°C)
P	DP Ports (1/8" NPT gauge ports)	500 PSIG (34 bar)	175°F (79°C)
V	Fluorocarbon O-rings	500 PSIG (34 bar)	175°F (79°C)
W	Auto Drain and DPI Indicator	250 PSIG (17 bar)	175°F (79°C)
X	Auto Drain and DP Ports	250 PSIG (17 bar)	175°F (79°C)
Y	Auto Drain and DGP Gauge	250 PSIG (17 bar)	175°F (79°C)



Other Compatible Accessories

TV-50 Timed Drain Valve	ZLD-013 Zero Loss Drain	VS-50 Visual Sump Drain (not shown: standard bowl guard)	MS-50 Metal Sump Drain (External)
210° F (99° C)	140° F (60° C)	125° F (52° C)	175° F (79° C)
300 PSIG (20 Bar)	232 PSIG (16 Bar)	150 PSIG (10 Bar)	250 PSIG (17 Bar)
1/2" NPT	1/2" NPT	1/2" NPT	1/2" NPT

Note: The accessories above are compatible with this product line, however, they are sold separately. Other timed drain valves can be found in Finite's Catalog 1300-300-06/USA.

*Note: Auto drains require a minimum operating pressure of 10 PSIG to seal.

Mounting brackets available: BK-M (1/4" - 1/2" connections); BK-3 (3/4" - 1" connections).

Step 4. How to Order

Use the steps below to build your own part number.
 For any permutation not mentioned below, please consult factory at 1-800-521-4357.

Step 2 or 2a				Step 1			Step 3
H	N	1 2	L - 6	C	U	G	
Series Name	Port Type	Port (Connection) Size	Bowl	Element Grade	Element Type	End Seal	Accessory Designator for preinstalled accessories
	N - NPT F - BSPP S - SAE* T - BSPT	1 - 1/4" 15 - 3/8" 2 - 1/2" 3 - 3/4" 4 - 1" 5 - 1 1/4" 6 - 1 1/2" 8 - 2" 0 - 2 1/2" 12 - 3"	S - Standard L - Long E - Economy (short bowl)* *Economy bowl is only available on 2" connection size. Note: Bowl length is determined by the flow rate required. See page 8, Housing Selection Chart, for flow rates.	4 6 8 10 Note: Grades are available on element type C, Q, D and I. For 7CVP, 7DVP, ME, 3P, 100WS and A, leave this blank.	C Q D I 3P 100WS A	Blank = No end seal, Standard on 1/4" to 1" connection sizes U = Urethane, Standard on 1 1/4" to 3" connection sizes S = Molded Silicone Rubber V = Fluorocarbon, Available 1 1/4" to 3" connections only U = Urethane, Standard all connection sizes S = Molded Silicone Rubber V = Fluorocarbon, Available 1 1/4" to 3" connections only S = Molded Silicone Rubber, Standard on all conn. sizes V = Fluorocarbon, Available 1 1/4" to 3" conn. sizes only Blank = Fluorocarbon, Standard on all 7CVP, 7DVP, and ME elements; elements available 1 1/4" to 3" connections only U = Urethane, Standard on 1/4" to 1" connection sizes U = Urethane, Standard on all connection sizes S = Molded Silicone Rubber V = Fluorocarbon, Available 1 1/4" to 3" connections only U = Urethane, Standard on 1/4" to 1" connection sizes Blank = Fluorocarbon, Standard on 100WS elements 1 1/4" to 3" connections only U = Urethane, Standard on all connection sizes S = Molded Silicone Rubber	A - Auto Drain D - DPI Indicator G - DPG Gauge (Standard on 3/4" & up) J - High Temperature (450°F) N - No Accessories P - 1/8" Differential (3/4" & up) Sensing Ports V - Fluorocarbon O-rings W - A + D X - A + P Y - A + G Note: For max. pressures and temperatures related to Accessories, please see chart on previous page.

Examples on How to Order

Example 1:
HN12L-6CUY
What am I ordering?
 An H-Series, with a 3" NPT connection, long bowl, standard grade 6 coalescing element with urethane end seals, an auto drain and a standard DPG gauge.

Example 2:
HN15L-8CA
What am I ordering?
 An H-Series, with a 3/8" NPT connection, long bowl, grade 8 coalescing element without end seals and an auto drain.

Example 3:
HN8S-7CVPG
What am I ordering?
 An H-Series, with a 2" NPT connection, standard bowl, a 7CVP coalescing element, with the standard fluorocarbon end seals and standard DPG gauge.

Example 4:
HN8E-10DVJ
What am I ordering?
 An H-Series, with a 2" NPT connection, economy short bowl, grade 10 high-temp coalescing element, with the standard fluorocarbon end seals and "J" as an accessory. This high temperature option converts all materials to be capable of handling temperatures of 450°F.

Example 5:
HN2S-AUN
What am I ordering?
 An H-Series, with a 1/2" NPT connection, short bowl, adsorber element, with the standard urethane end seals and no accessories.

Drawings, Dimensions & Specifications

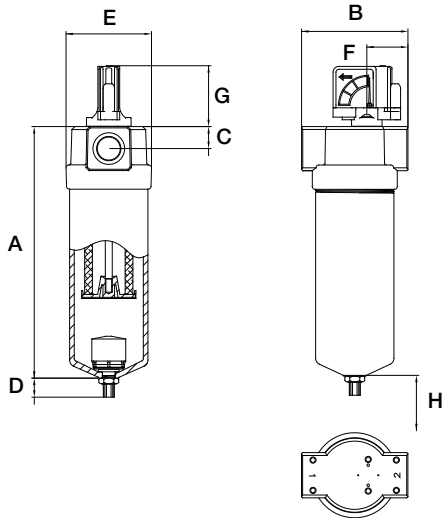

1/4" to 1" Port Size Housings

Specifications

Max. Pressure: 500 PSIG (34 bar)
Safety Factor: Max. operating to burst 4:1
Max. Temp.: 175°F (79°C) with option to 450°F (232°C)
Seals: Nitrile Std./Fluorocarbon optional
Materials: Aluminum - 380 Die cast heads;
 6061 Drawn bowls
Coatings: Chromated heads and bowls;
 Powder painted exterior
Design: In-line threaded bowl to head

Note: Manual Drain Port is 1/8" FNPT when tee valve is removed from drain bushing.

Model	A	B	C	D	E	F	G	H*	Sump (ml)	Weight
H_1S	6.80 (172)	3.12 (79)	.63 (16)	.79 (20)	2.98 (76)	1.56 (39.5)	2.6 (66)	2.99 (76)	150	1.49 (.68)
H_15S	6.80 (172)	3.12 (79)	.63 (16)	.79 (20)	2.98 (76)	1.56 (39.5)	2.6 (66)	2.99 (76)	150	1.47 (.66)
H_2S	6.80 (172)	3.12 (79)	.63 (16)	.79 (20)	2.98 (76)	1.56 (39.5)	2.6 (66)	2.99 (76)	150	1.44 (.65)
H_1L	9.19 (233)	3.12 (79)	.63 (16)	.79 (20)	2.98 (76)	1.56 (39.5)	2.6 (66)	5.51 (140)	140	1.89 (.86)
H_15L	9.19 (233)	3.12 (79)	.63 (16)	.79 (20)	2.98 (76)	1.56 (39.5)	2.6 (66)	5.51 (140)	140	1.87 (.85)
H_2L	9.19 (233)	3.12 (79)	.63 (16)	.79 (20)	2.98 (76)	1.56 (39.5)	2.6 (66)	5.51 (140)	140	1.85 (.84)
H_3S	10.86 (276)	4.65 (118)	.96 (24)	.79 (20)	3.68 (93.5)	1.73 (44)	2.6 (66)	6.5 (165)	270	3.56 (1.61)
H_4S	10.86 (276)	4.65 (118)	.96 (24)	.79 (20)	3.68 (93.5)	1.73 (44)	2.6 (66)	6.5 (165)	270	3.29 (1.49)
H_4L	14.36 (365)	4.65 (118)	.96 (24)	.79 (20)	3.68 (93.5)	1.73 (44)	2.6 (66)	10.00 (254)	270	4.11 (1.86)

Special Note: Dimensions are in inches (millimeters); weight is in pounds (kilograms).

* Clearance required to remove bowl.

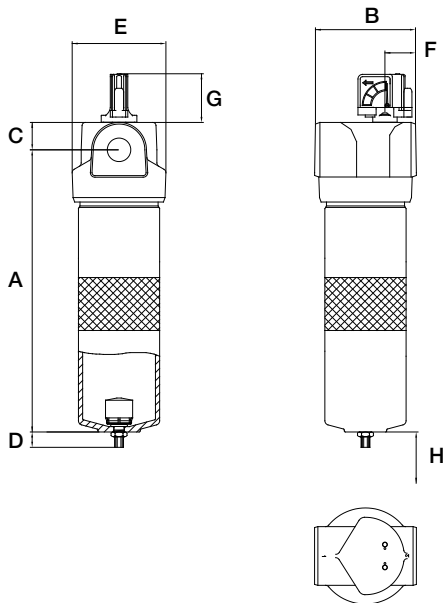

1 1/4" to 3" Port Size Housings

Specifications

Max. Pressure: 500 PSIG (34 bar)
Safety Factor: Max. operating to burst 4:1
Max. Temp.: 175°F (79°C) with option to 450°F (232°C)
Seals: Nitrile Std./Fluorocarbon optional
Materials: Aluminum - 356 Sand cast heads;
 6061 Drawn bowls
Coatings: Chromated heads and bowls;
 Powder painted exterior
Design: In-line threaded bowl to head

Note: Manual Drain Port is 1/8" FNPT when tee valve is removed from drain bushing.

Model	A	B	C	D	E	F	G	H*	Sump (ml)	Weight
H_5S	18.23 (463)	6.0 (152)	1.65 (42)	.83 (21)	5.67 (144)	1.85 (47)	2.6 (66)	13.50 (343)	440	12.11 (5.49)
H_6S	18.23 (463)	6.0 (152)	1.65 (42)	.83 (21)	5.67 (144)	1.85 (47)	2.6 (66)	13.50 (343)	440	11.97 (5.43)
H_8E	18.23 (463)	6.0 (152)	1.65 (42)	.83 (21)	5.67 (144)	1.85 (47)	2.6 (66)	13.50 (343)	440	11.97 (5.43)
H_8S	24.23 (617)	6.0 (152)	1.65 (42)	.83 (21)	5.67 (144)	1.85 (47)	2.6 (66)	19.25 (489)	530	14.00 (6.35)
H_8L	29.23 (742)	6.0 (152)	1.65 (42)	.83 (21)	5.67 (144)	1.85 (47)	2.6 (66)	24.02 (610)	620	15.99 (7.25)
H_0L	35.70 (907)	8.0 (203)	2.4 (61)	.83 (21)	7.24 (184)	2.36 (60)	2.6 (66)	28.50 (724)	880	35.00 (15.87)
H_12L	35.70 (907)	8.0 (203)	2.4 (61)	.83 (21)	7.24 (184)	2.36 (60)	2.6 (66)	28.50 (724)	880	34.14 (15.48)

Special Note: Dimensions are in inches (millimeters); weight is in pounds (kilograms).

* Clearance required to remove bowl.

North America

Engine Filtration

Parker Hannifin Corporation
Racor Division
 3400 Finch Road
 P.O. Box 3208
 Modesto, CA 95354
 phone 209 521 7860
 fax 209 529 3278
 www.parker.com/racor

Parker Hannifin Corporation
Racor Division
 P.O. Box 6030
 Holly Springs, MS 38635
 phone 662 252 2656
 fax 662 274 2118
 www.parker.com/racor

Parker Hannifin Corporation
Racor Division
 302 Parker Drive
 Beaufort, SC 29906
 phone 843 846 3200
 fax 843 846 3230
 www.parker.com/racor

Compressed Air Treatment

Parker Hannifin Corporation
**Filtration and Separation
 Balston Operation**
 242 Neck Road
 Haverhill, MA 01835-0723
 phone 978 858 0505
 fax 978 858 0625
 www.parker.com/balston

Parker Hannifin Corporation
**Filtration and Separation
 Finite Filter Operation**
 500 Glaspie Street
 P.O. Box 599
 Oxford, MI 48371-5132
 phone 248 628 6400
 fax 248 628 1850
 www.parker.com/finitefilter

Parker Hannifin Corporation
Airtek Division
 4087 Walden Avenue
 Lancaster, NY 14086
 phone 716 685 4040
 fax 716 685 1010
 www.airtek.com

Hydraulic Filtration

Parker Hannifin Corporation
Hydraulic Filter Division
 16810 Fulton County Road #2
 Metamora, OH 43540-9714
 phone 419 644 4311
 fax 419 644 6205
 www.parker.com/hydraulicfilter

Process Filtration

Parker Hannifin Corporation
Process Advanced Filtration
 2340 Eastman Avenue
 Oxnard, CA 93030
 phone 805 604 3400
 fax 805 604 3401
 www.parker.com/processfiltration

Europe

Engine Filtration

Parker Hannifin Corporation
Filter Division Europe
 Shaw Cross Business Park
 Churwell Vale
 Dewsbury, WF12 7RD England
 phone +44 (0) 1924 487000
 fax +44 (0) 1924 487038
 www.parker.com/eurofilt

Compressed Air Treatment

Parker Hannifin Corporation
domnick hunter industrial operations
 Dukeway, Team Valley Trading Estate
 Gateshead, Tyne & Wear
 England NE11 0PZ
 phone +44 (0) 191 402 9000
 fax + 44 (0) 191 482 6296
 www.domnickhunter.com

Parker Hannifin Corporation
Parker Hiross S.p.A.
 Strada Zona Industriale, 4
 35020, S. Angelo di Piove(PD), Italy
 phone +39 049 9712 111
 fax +39 049 7001 111
 www.dh-hiross.com

Parker Hannifin Corporation
ZANDER Aufbereitungstechnik GmbH
 Stammhaus Essen/Headquarter
 Germany, Essen
 Im Teelbruch 118
 45219 Essen
 phone +49 (0) 20 54 93 40
 fax + 49 (0) 20 54 93 41 64
 www.zander.de

Hydraulic Filtration

Parker Hannifin Corporation
Hydraulic Filtration Division Europe
 Stieltjesweg 8, 6827 BV Arnhem
 P.O. Box 5008 6802 EA, Arnhem
 Arnhem, Holland
 phone +31 26 3760376
 fax +31 26 3643620
 www.parker.com/eurofilt

Parker Hannifin Corporation
Finn Filter Operation
 Salmentie 260
 FI-31700 Urjala as Finland
 phone +358 20 753 2500
 fax +358 20 753 2501
 www.parker.com/fi

Parker Hannifin Corporation
CMC Operation
 Brunel Way
 Thetford, Norfolk IP 24 1HP England
 phone +44 1842 763299
 fax +44 1842 756300
 www.parker.com/cmc

Process Filtration

Parker Hannifin Corporation
domnick hunter process division
 Durham Road, Birtley
 Co. Durham, DH3 2SF England
 phone +44 (0) 191 410 5121
 fax +44 (0) 191 410 5312
 www.domnickhunter.com

Asia Pacific

Parker Hannifin Corporation
Shanghai Co. Ltd.
 280 YunQiao Road
 JinQiao Export Processing Zone
 Shanghai 101206 China
 phone +86 21 5031 2525
 fax +86 21 5834 3714
 www.parker.com/china

Parker Hannifin Corporation
Singapore Pte Ltd.
 Lot 558A, Jalan Subang 3
 Off Persiaran Subang
 Sungai Penaga Industrial Park
 47610 Subang Jaya
 Selangor Darul Ehsan, Malaysia
 phone +60 3 5638 1476
 fax +60 3 5638 1527
 www.parker.com/malaysia

Parker Hannifin Corporation
Thailand Co. Ltd.
 1023 3rd Floor, TPS Building
 Pattanakam Road
 Suanluang, Bangkok 10250 Thailand
 phone +66 2717 8140
 fax +66 2717 8148
 www.parker.com/thailand

Parker Hannifin Corporation
Korea Ltd.
 777 Jung-Ri
 Dongtan-Myeon, Hwaseong-City
 Kyunggi-Do, 445-813 Korea
 phone +82 31 379 2200
 fax +82 31 377 9710
 www.parker.com/korea

Latin America

Parker Hannifin Corporation
Comercio Ltda. Filtration Division
 Estrada Municipal Joel de Paula, 900
 Eugenio de Melo, Sao Jose dos Campos
 CEP 12225-390 SP Brazil
 phone +55 (12) 4009 3500
 fax +55 (12) 4009 3529
 www.parker.com/br

© 2008 Parker Hannifin Corporation
 March 2008 / Bulletin 1300-993C/USA

Parker Hannifin Corporation
Finite Filter Operation
 500 Glaspie Street
 Oxford, MI 48371
 phone 248 628-6400
 fax 248 628-1850
 www.parker.com/finitefilter

